



FEATURES

- Wide flow range
- One moving part
- Hot tap available
- Modular electronics compatible
- Easily depth adjustable for 3-48" pipe

APPLICATIONS

- Clean water
- Large pipes
- Aquariums, water parks
- Water & wastewater monitoring

GENERAL INFORMATION

The **IP100/200-Series** are adjustable depth insertion paddlewheels that come in brass or 316 stainless models to fit 3" to 48" pipe. Installation fittings are standard 1-1/2" (101/201) or 2" (115/215) NPT. Fittings such as saddles and weldolets may be purchased either locally or from SeaMetrics.

Ruby bearings and a non-drag Hall-effect sensor give these meters the widest flow range of any of the paddlewheel types. A sensor detects the passage of miniature magnets in the six rotor blades. The resulting square-wave signal can be sent for hundreds of feet over unshielded cable without a transmitter and connected directly to many PLC's and other controls without any additional electronics.

If desired, a modular system of electronics can be installed directly on the flow sensor or mounted remotely. The FT415 (battery powered) or FT420 (loop powered) flow indicator provides digital rate and total display, as well as programmable pulse output; the FT420 also provides a 4-20 mA analog output. If a display is not required, the AO55 provides 4-20 mA analog output, and the PD10 provides a programmable pulse for pump pacing.

The "hot-tap" models (IP115/215) can be installed or serviced without shutting down the line by means of a 2" full-port isolation valve that comes with a nipple for installation on the pipe fitting. In most circumstances, no special tool is required.

FEATURES

Modular electronics (optional)

- rate/total/pulse/4-20 mA
- blind 4-20 transmitter
- pulse divider

18 Foot Cable

Rugged cast aluminum housing

Compression nut
for easy adjustment, secure locking

Adapter fitting
with 1-1/2" NPT threads

Rotor housing

Removable jewel bearings

Rotor

IP101/201

3/4" diameter tubing
for low insertion force

2" Adapter
removes to mount
hot-tap machine

Full-port 2" ball valve
for sensor removal

Adapter fitting
with 2" NPT threads

Locking collar

IP115/215

SPECIFICATIONS *

Pipe Size		IP101/115	IP201/215
		3" to 10" (50 - 250mm)	10" to 48" (250 - 1200mm)
Sensor		Hall Effect sensor, 12 Vdc current sinking pulse	
Materials	Housing	Cast aluminum	
	Sensor Body	Brass or 316 SS	
	Rotor	PVDF (Kynar)	
	Shaft	Nickel-bound tungsten carbide (zirconia ceramic optional)	
	Bearings	Ruby jewel	
Isolation Valve		IP101/201	IP115/215
		None	Bronze (316SS optional)
Fitting Size		1.5" NPT	2" NPT
Flow Range		0.3 - 30 feet/sec (0.1 - 9 meter/sec)	
Accuracy		+/- 1.5% of full scale	
Maximum Temperature		200° F (93° C)	
Maximum Pressure		200 psi (14 bar)	
Insertion Force		0.44 x pressure in pipe	
Power		5-24 Vdc, 1.5 mA	
Cable		#22 AWG 3-con, 18' (6m); 2,000' (650m) maximum cable run	

*Specifications subject to change. Please consult our website for the most current data (www.seametrics.com).

DIMENSIONS

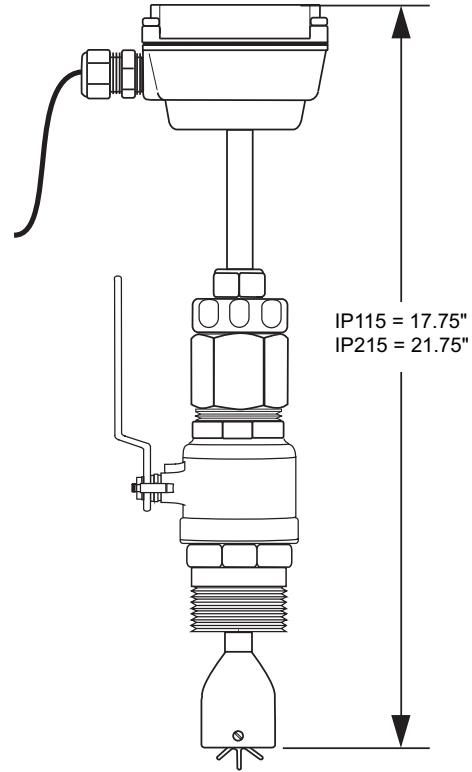
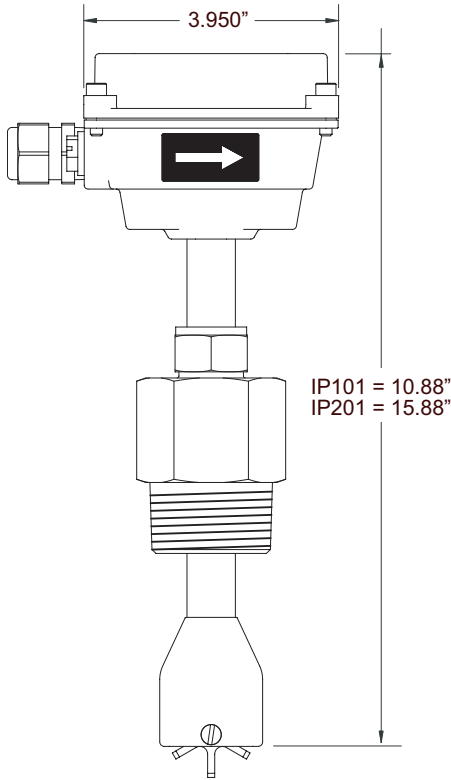

HOT TAP INSTALLATION

Insertion and removal under pressure is possible due to the 2" full-port isolation valve, which comes with a nipple for installation on the pipe fitting. If it is necessary to do the initial installation under pressure, any standard hot tap drilling machine with 2" NPT adapter, such as a Transmate or a Mueller, can be used. Ordinarily, it is not necessary to use an installation tool, since the small-diameter tube can be controlled by hand at all but the highest pressures.

HOT TAP REMOVAL

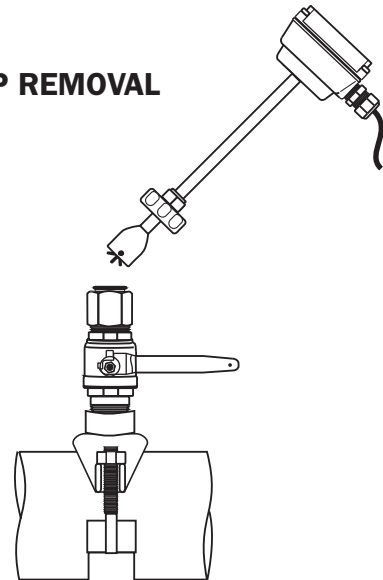

FLOW RANGE (Gallons Per Minute)

Pipe Size	3"	4"	6"	8"	10"	12"	16"	18"	24"	30"	36"	48"
Min. (.3 ft/sec)	7	12	30	50	75	100	175	225	400	640	900	1,600
Max. (30 ft/sec)	700	1,100	2,500	4,500	7,000	10,000	16,000	22,000	35,000	64,000	90,000	160,000

Approximations based on Schedule 40 pipe.



IP100/200-SERIES Insertion Paddlewheel Flow Sensor

HOW TO ORDER

MODEL

3-10" = **IP101**
3-10" hot tap = **IP115**
10-48" = **IP201**
10-48" hot tap = **IP215**

MATERIAL

Brass = **B**
316 Stainless = **S**

OPTIONS

Ceramic Shaft = **-01**
Adapter Fitting, 2" Threads = **-02**
Micropower Pickup (FT415 & DL75 Only) = **-04**
LMI Pump Connector = **-06**
SeaMetrics Control Connector = **-07**
Stainless Valve Assembly (115/215 only) = **-08**
No Valve Assembly (115/215 only) = **-09**
*Immersibility = **-40**
12" Extension (200-Series only) = **-72**

*Consult factory for suitable applications

ACCESSORIES

Rate & Total Indicator w/4-20 mA Output = **FT420**
Battery Operated Rate/Totalizer = **FT415**
Blind 4-20 mA Transmitter = **AO55**
Power Supply = **PC3**

Data Logger = **DL75**
Pulse Divider = **PD10**
Saddle Fittings = **Consult Factory**

CONTACT YOUR SUPPLIER