

Instruction Sheet

Liquitron™ DP5000/DR5000 Series 4-20 mA Option Board Part # 37830



Ensure that the controller is turned off and the power cord is disconnected from the outlet before attempting to install the 4-20 mA option board. The option board has very fragile pins, which are protected by anti-static foam for shipping. Please use extreme care in handling. The circuit can be damaged by electrostatic discharge or rough handling. ESD protection is recommended.

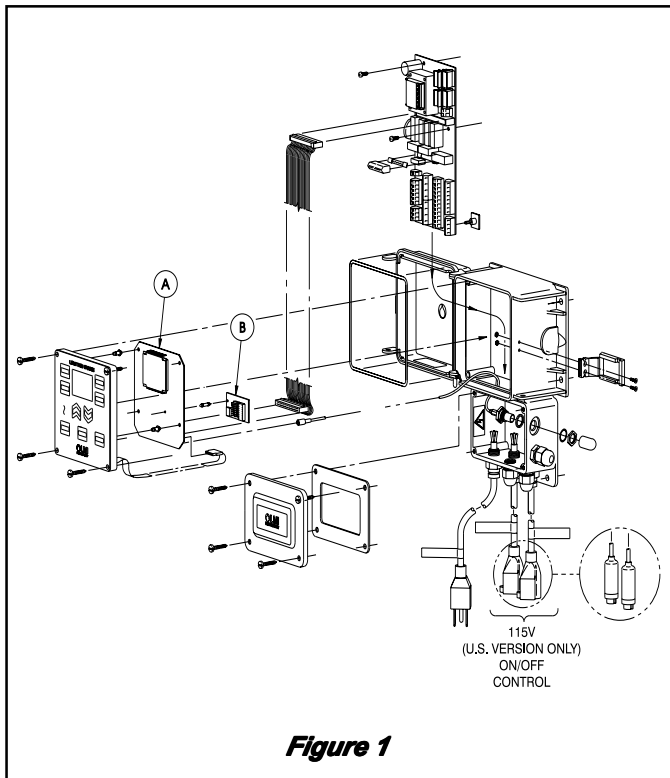
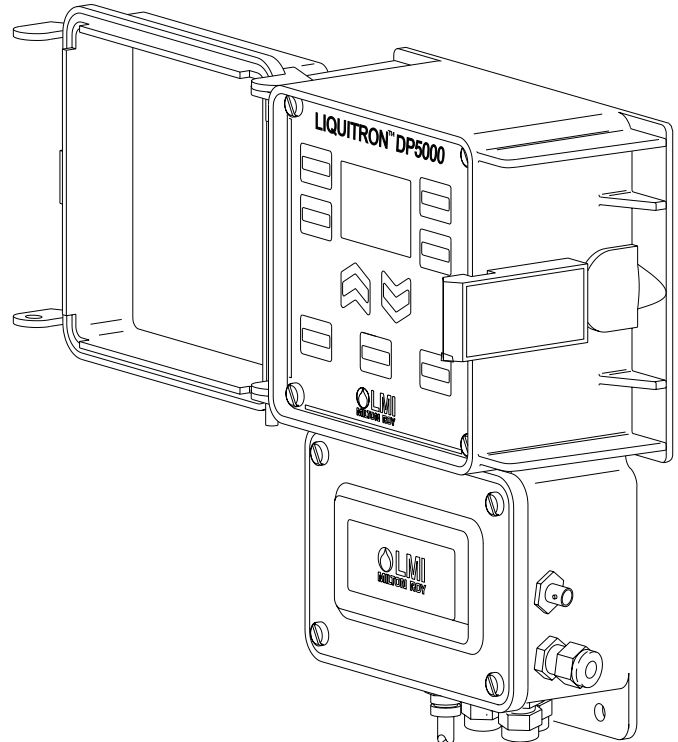

Figure 1

1. Disconnect AC power and open the front clear plastic cover. Remove the four screws from the top keypad display panel (see Figure 1).
2. Remove the keypad panel from the controller. **Do Not disconnect the keypad from the cable ribbon.**



8 Post Office Square
Acton, MA 01720 USA
TEL: (978) 263-9800
FAX: (978) 264-9172
<http://www.lmipumps.com>



